

Pro Melt



Pro Melt



PELLETIZING KNIFE

GRANULATOR KNIFE

PELLETIZING DIE

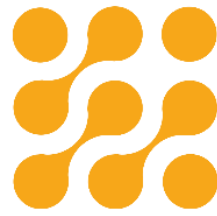

Pro Melt



Underwater Pelletizing Die

We offer underwater pelletizing dies with Tungsten Carbide inserts.



Water ring Pelletizing Die

Our Water ring Pelletizing dies are made out D2 steel, vacuum hardened.





Pro Melt



Strand Pelletizing Rotor

We produce cutting rotors for strand pelletizers according to OEM specifications.

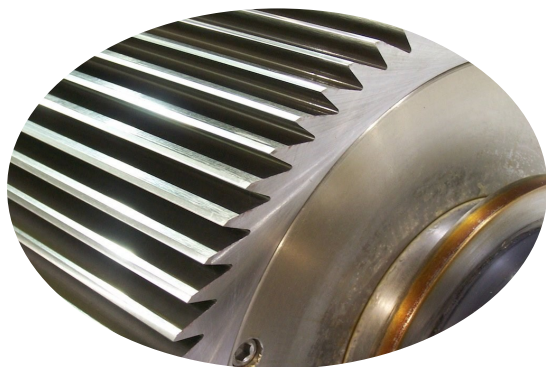

Custom produced rotors according to drawings or samples can be provided.

We offer strand pelletizing rotors with Moc 1.4112/ws01, Moc SI03/ Stellite & Moc: Tungsten Carbide.

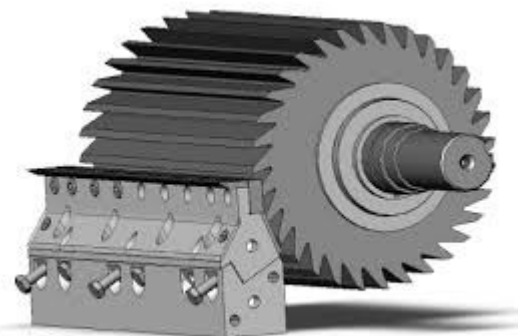

CUTTING ROTORS

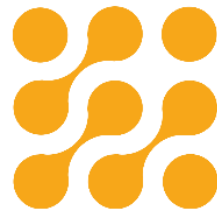

Pro Melt



Pelletizing Blades for Underwater and Watering Pelletizers



- Pelletizer Blades are small but significant component of good granule production in the plastic compounding industry.
- Promelt Blades deliver excellent cutting performance with long life due to its superior wear resistance.
- With our experience in cutting process and Tool Making, we manufacture blades which last longer and deliver consistent performance over the life of the blade.
- We can manufacture blades to your specific requirements.

Materials Used

Promelt uses HSS from reputed manufacturers like BOHLER Austria, Erasteel France, Edelstahl Germany.

Commonly used steels are: D2, M2, M35, & PM steels with vacuum heat treatment.

Granulator Blades

Excellent quality Granulator blades
manufactured from Imported D2
material with heat treatment

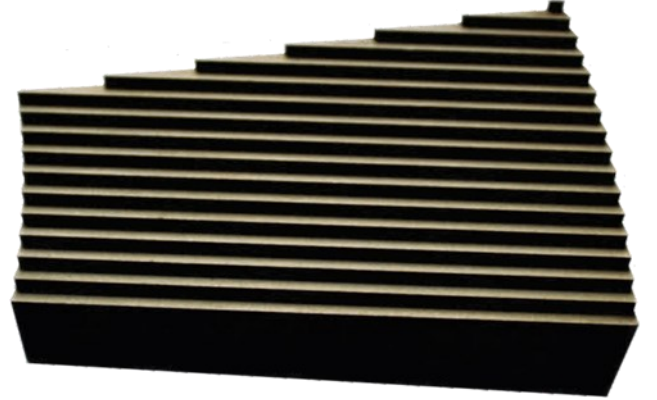

CONTACT



PROMELT MAKİNE KİMYA SANAYİ VE TİC. LTD.ŞTİ.

Özgürlük Mah. Mehmet Akif Ersoy Caddesi, 219 Sokak, No: 5

Çayırova/KOCAELİ

+90 551 233 37 96 | +90 532 296 62 03

info@pro-melt.com.tr | sales@pro-melt.com.tr

www.pro-melt.com.tr

ACCESSORIES