



# STRAND PELLETIZERS

Your system supplier for plastic pellets

## Technical Specification

Technical Data		PL 70
Feed width (mm)		70
drive type		Inverter
installed rating (kW)		3
strand speed $V_e$ (m/mim.) min./max.		30-90
max. number of strands at 3mm strand-Ø		10
Pellet length (mm)		3
dimensions (mm)	A	650
	B	approx, 1600
	C	750
	D	70
	E	160
	F	195
	G	950
	H	170

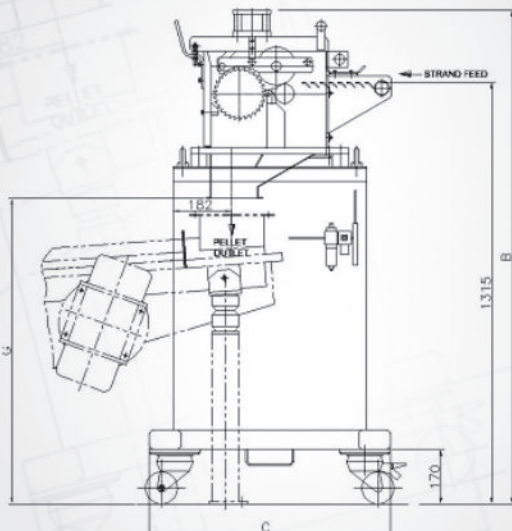
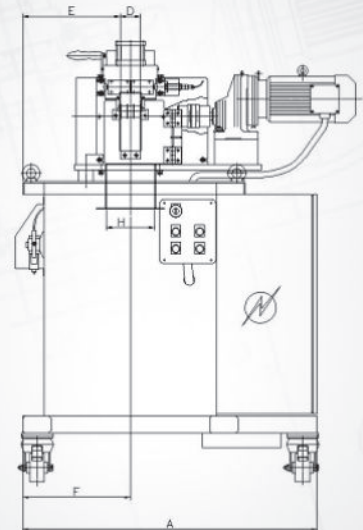

Production capacity in kg/hr  
(approximate value of strandspeed=90 m/min)

Product	PL 70
PET	500
HIPS, PMMA, GPPS, ABS, SAN	390
PA 6.6	430
PA 6 n.e.	425
PC	450
PPPE	345
PET + 30% GF	585
PA + 30% GF	520
number of strands	10

LMFL Strand Pelletizer - the most economical Strand Pelletizer

- Thruput in kg/hr (Pellet dia and length 3mm each)
- Max. thrupt can vary depend on your product & pellet size.

All specs. Shown are subject to change.